

JHARKHAND RAI UNIVERSITY



CIVIL ENGINEERING

LAB MANUAL

STRUCTURAL ENGINEERING

EXPERIMENT NO. 1

Aim: - To verify strain in an externally loaded beam with the help of a strain gauge indicator and to verify theoretically.

Apparatus: - Strain gauge Indicator, weights, hanger, scale, vernier caliper.

Formula: - $f = \frac{M}{I} y$

Theory : - When a beam is loaded with some external loading, moment & shear force are set up at each strain. The bending moment at a section tends to deflect the beam & internal stresses tend to resist its bending. This internal resistance is known as bending stresses.

Following are the assumptions in theory of simple bending.

1. The material of beam is perfectly homogeneous and isotropic (i.e. have same elastic properties in all directions.)
2. The beam material is stressed to its elastic limits and thus follows Hook's law.
3. The transverse section which are plane before bending remains plane after bending also.
4. The value of young's modulus of elasticity 'E' is same in tension and compression.

The bending stress at any section can be obtained by beam equation.

$$f = (M/I) y$$

Where, M= moment at considered section.

f = extreme fiber stresses at considered section. I = Moment of inertia at that section.

y= Extreme fiber distance from neutral axis.

f_{\max} = maximum stress at the farthest fiber i.e. at y_{\max} from neutral axis.

Digital strain indicator is used to measure the strain in static condition. It incorporates basic bridge balancing network, internal dummy arms, an amplifier and a digital display to indicate strain value.

In resistance type strain gauge when wire is stretched elastically its length and diameter gets altered. This results in an overall change of resistance due to change in both the dimensions. The method is to measure change in resistance, which occurs as a result of change in the applied load.

Strain can be calculated analytically at the section by using Hook's law. Distrainindicator is used to measure the extreme fiber at particular section. It basically incorporates basic bridge balancing network, internal dummy arms, amplifier & digital display to indicate strain value.

Two -Arm Bridge requires two strain gauge and will display the strain value two times of actual. Four -Arm Bridge requires four strain gauge and will display the strain value four times of actual.

Procedure: -

- i) Mount the beam with hanger, at the desired position and strain gauges, over it supports properly and connect the strain gauges to the digital indicator as per the circuit diagram.
- ii) Connect the digital indicator to 230(+/- 10%) volts 50 Hz single phase A.C. power supply and switch 'ON' the apparatus.
- iii) Select the two/four arm bridge as required and balance the bridge to display a '000' reading.
- iv) Push the 'GF READ' switch and adjust the gauge factor to that of the strain gauge used (generally 2.00)
- v) Apply load on the hanger increasingly and note the corresponding strain value.

- Observation: -**
- 1) Width of the beam model, B (cm) =
 - 2) Depth of the beam model, D (cm) =
 - 3) Span of the beam, L (cm) =
 - 4) Moment of inertia of beam, I =
 - $Y_{max} = D/2$ =
 - 5) Modulus of elasticity of beam material, E =

Observation Table:-

S.No	Load applied on the hanger P (kg)	Moment at the mid span section (kg cm) = PL/4	$f_{max} = (M/I) Y_{max}$	Theoretical Strain $\phi = \frac{f_{max}}{E}$	Observed strain on the display
1					
2					
3					
4					
5					

Sample Calculation: - For reading No.

- Load applied on the hanger P (kg)
- Moment at the mid span section (kg cm) = PL/4
- $f_{max} = (M/I) Y_{max}$
- Theoretical Strain $\phi = \frac{f_{max}}{E}$
- Observed strain on the display

Result : - From observation table, it is seen that, the theoretical and observed value of strain is same.

EXPERIMENT NO. 2

Aim: - To study behavior of different types of columns and find Euler's buckling load for each case.

Apparatus: - Column Buckling Apparatus, Weights, Hanger, Dial Gauge, Scale, Vernier caliper.

Diagram:-

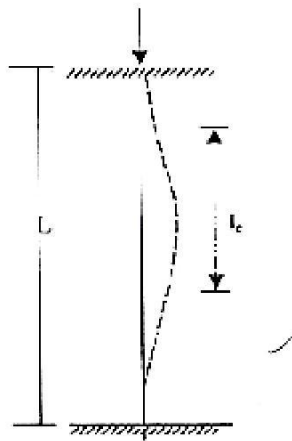

(i) Both ends fixed

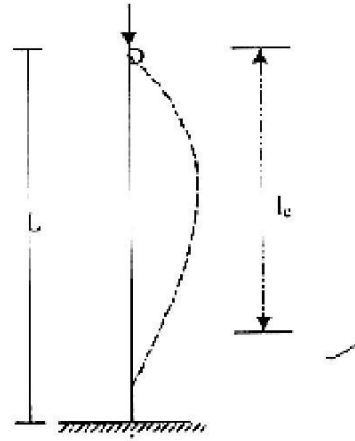

(ii) One end fixed other pinned

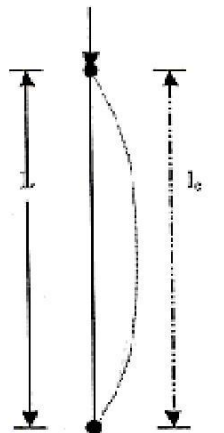

(iii) Both ends pinned

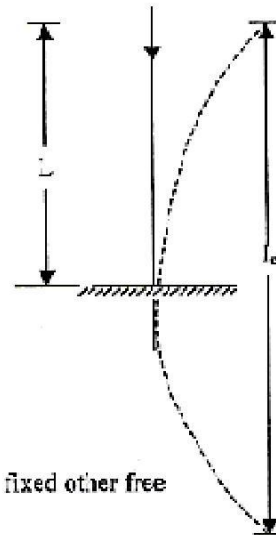

(iv) One end fixed other free

Theory :-If compressive load is applied on a column, the member may fail either by crushing or by buckling depending on its material, cross section and length. If member is considerably long in comparison to its lateral dimensions it will fail by buckling. If a member shows signs of buckling the member leads to failure with small increase in load. The load at which the member just buckles is called as crushing load. The buckling load, as given by Euler, can be found by using following expression.

$$P = \frac{\pi^2 EI}{l_e^2}$$

Where,

E = Modulus of Elasticity =

$2 \times 10^5 \text{ N/mm}^2$ for steel

I = Least moment of inertia of column section

Le = Effective length of column

Depending on support conditions, four cases may arise. The effective length for each of which are given as:

1. Both ends are fixed $l_e = L/2$
2. One end is fixed and other is pinned $l_e = L/\sqrt{2}$
3. Both ends are pinned $l_e = L$
4. One end is fixed and other is free $l_e = 2L$

Procedure: -

- i) Pin a graph paper on the wooden board behind the column.
- ii) Apply the load at the top of columns increasing gradually. At certain stage of loading the columns shows abnormal deflections and gives the buckling load.
- iii) Note the buckling load for each of the four columns.
- iv) Trace the deflected shapes of the columns over the paper. Mark the points of change of curvature of the curves and measure the effective or equivalent length for each case separately.
- v) Calculate the theoretical effective lengths and thus buckling loads by the expressions given above and compare them with the observed values.

Observation: -

- 1) Width of strip (mm) $b =$
- 2) Thickness of strip (mm) $t =$
- 3) Length of strip (mm) $L =$
- 4) Least moment of inertia $I = \frac{bt^3}{12}$

Observation Table:-

Sr. No	End condition	Euler's Buckling load		Effective Length (mm)	
		Theoretical	Observed	Theoretical	Observed
1	Both ends fixed				
2	One end fixed and other pinned				
3	Both ends pinned				
4	One end fixed and other free.				

Sample Calculation: - End condition: Both ends fixed

$$\text{Euler's buckling load.} = P = \frac{\pi^2 EI}{l_e^2}$$

Effective Length (mm) =.

Result :-The theoretical and experimental Euler's buckling load for each case is found nearly same.

EXPERIMENT NO. 3

Aim: - To study two hinged arch for the horizontal displacement of the roller end for a given system of loading and to compare the same with those obtained analytically.

Apparatus: - Two Hinged Arch Apparatus, Weight's, Hanger, Dial Gauge, Scale, Verniar Caliper.

Formula: - $H = \frac{5WL}{a^4} (a - 2a^3 + 8r)$

Where,

W= Weight applied at end support.

L= Span of two hinged arch.

r= rise of two hinged arch.

a = dial gauge reading.

Diagram:-

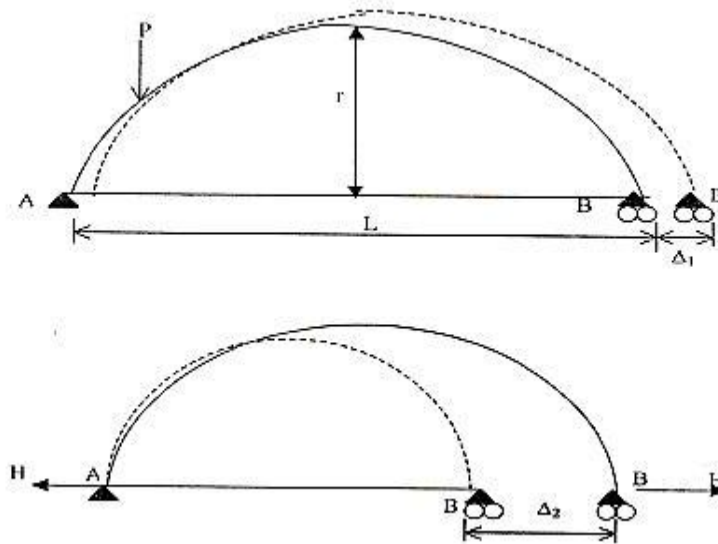

Theory :-The two hinged arch is a statically indeterminate structure of the first degree. The horizontal thrust is the redundant reaction and is obtained by the use of strain energy methods. Two hinged arch is made determinate by treating it as a simply supported curved beam and horizontal thrust as a redundant reaction. The arch spreads out under external load. Horizontal thrust is the redundant reaction is obtained by the use of strain energy method.

Procedure: -

- i) Fix the dial gauge to measure the movement of the roller end of the model and keep the lever out of contact.
- ii) Place a load of 0.5kg on the central hanger of the arch to remove any slackness and taking this as the initial position, set the reading on the dial gauge to zero.

iii) Now add 1 kg weights to the hanger and tabulated the horizontal movement of the roller end with increase in the load in steps of 1 kg. Take the reading up to 5 kg load. Dial gauge reading should be noted at the time of unloading also.

iv) Plot a graph between the load and displacement (Theoretical and Experimental) compare. Theoretical values should be computed by using horizontal displacement formula.

v) Now move the lever in contact with 200gm hanger on ratio 4/1 position with a 1kg load on the first hanger. Set the initial reading of the dial gauge to zero.

vi) Place additional 5 kg load on the first hanger without shock and observe the dial gauge reading.

vii) Restore the dial gauge reading to zero by adding loads to the lever hanger, say the load is w kg.

viii) The experimental values of the influence line ordinate at the first hanger position shall be $\frac{4w}{5}$.

ix) Repeat the steps 5 to 8 for all other hanger loading positions and tabulate. Plot the influence line ordinates.

x) Compare the experimental values with those obtained theoretically by using equation. (5).

Observation Table:-

Table: - 1
Horizontal displacement

Sr.No.	Central load (kg)	0.0	1.0	2.0	3.0	4.0	5.0	6.0
	Observed horizontal Displacement (mm)							
	Calculated horizontal Displacement Eq. (4)							

Sample Calculation: - Central load (kg) =.....
 Observed horizontal Displacement (mm). =
 Calculated horizontal Displacement = $H = \frac{5WL}{4} (a - 2a^3 + a^4) 8r$
 =.....

Result :-The observed and horizontal displacement is nearly same.

Precaution :- Apply the loads without jerk.
 :- Perform the experiment away from vibration and other disturbances.

EXPERIMENT NO. 4

Aim : - To study the behavior of a portal frame under different end conditions.

Apparatus : - Portal Frame Apparatus, Weight's, Hanger, Dial Gauge, Scale, Verniar caliper.

Formula : - $P h/2 - R_{cy} b = 0$, $R_{cy} = ph/2b$

Diagram:-

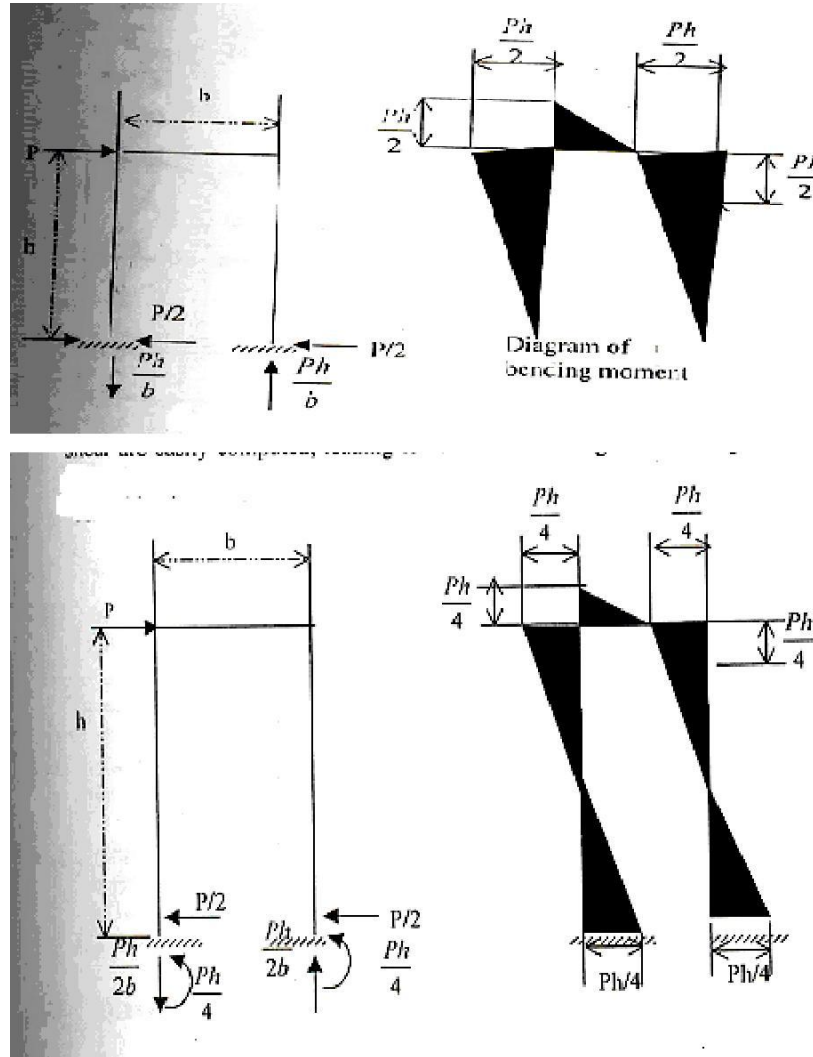

Theory : - Structures are categorized as statically determinate or as statically indeterminate. Determinate structures can be analysed additional conditions to solve. The portal frame is an indeterminate structure to several degree of indeterminacy depending on the end conditions.

To know the behavior of any frame it is advisable to know its different deflected shapes under different loading condition, which can be obtained by vertical work energy method analytically.

Portal structures similar to the end portals of bridge have as their primary purpose, the transfer of horizontal loads applied at their top to their foundations. Clearance requirements usually lead to the use of statically indeterminate structure layout for portals, and approximate solutions are often used in their analysis.

Consider the portal shown in all the member of which are capable of carrying bending and shear as well as axial force. The legs are hinged at their base and rigidly connected to the cross girder at the top. This structure is statically indeterminate to the first degree; hence, one assumption must be made. Solution of this type of structure based on elastic considerations, show that the total horizontal shear on the portal will be divided almost equally between the two legs; it will therefore be assumed that the horizontal reactions for the two legs are equal to each other and therefore equal to $P/2$. The remainder of the analysis can now be carried out by static. The vertical reaction on the right leg can be obtained by taking moment about the hinge at the base of the left leg. The vertical reaction on the left leg can then be found by applying $\sum f_y = 0$ to the entire structure. Once the reactions are known, the diagrams of bending moment and shear are easily computed, leading to values for bending moment as given in fig (b). It is well to visualize the deformed shape of the portal under the action of the applied load.

Consider now portal similar in some ways to of fig. (a) but with the bases of the legs fixed as shown in fig(c) This structure is statically indeterminate to the third degree, so that three assumptions must be made. As when the legs were hinged at their base, it will again be assumed that the horizontal reaction for the two legs are equal and hence equal to $P/2$. It will be noted that near the center of each leg there is point of reversal of curvature. These are points of inflection, where the bending moment is changing sign and hence has zero value.

Procedure: -

- i) Select the end conditions of the portal frame.
- ii) Select the point where loading is to be applied (first horizontal than vertical separately).
- iii) To obtain the deflected shape of the frame, measure the deflection at various points at legs and the beam separately as detailed below.
- iv) Fix the dial gauge and adjust them to zero on one of the leg at various points and measure the vertical distance from the end of these points.
- v) Now apply the load at the point selected for loading.
- vi) Note down the dial gauge readings
- vii) Unload the frame and shift the dial gauge to another leg and repeat the above (4), (5). (6).
- viii) Again unload the frame and shift the dial gauge to the beam of the frame and repeated (4), (5). (6).
- ix) Tabulate the observed reading and sketch the deflected shape for the portal frame on the graph sheet.
- x) Repeat the above steps (1) to (9) for various ends conditions and loading conditions to obtain the deflected shape.

Observation Table:-

Table: - 1

Points on AC	Distance of Point from C	Dial gauge reading		Deflections (mm)
		Initial	Final	

Table: - 2

Points on AB	Distance of Point from A	Dial gauge reading		Deflections (mm)
		Initial	Final	

Table: - 3

Points on BD	Distance of Point from D	Dial gauge reading		Deflections (mm)
		Initial	Final	

Sample Calculation: - 1) Portal frame with end conditions =
 2) Loading point x on AC/AB/BD
 Load applied = kg

Result : - The horizontal displacement obtained theoretically and experimentally is nearly same,

Precaution : - Apply the load without jerk.
 : - Perform the experiment away from vibration and other disturbances.

EXPERIMENT NO. 5

Aim: - To find the value of flexural rigidity (EI) for a given beam and compare it with theoretical value.

Apparatus: - Elastic Properties of deflected beam, weight's, hanger, dial gauge, scale, and Verniar caliper.

Formula: - (1) Central upward deflection, $y = w.a.L^2 / 8y$ (1)

(2): $EI = w.a. L^2 / 8y$ (2)

(3) Also it is known that EI for beam = $E \times bd^3 / 12$ (3)

Diagram:-

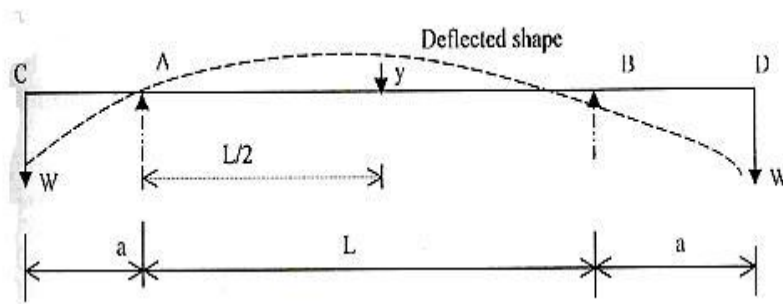

Theory :-For the beam with two equal overhangs and subjected to two concentrated loads W each at free ends, maximum deflection y at the centre is given by central upward deflection.

Central upward deflection, $y = w.a.L^2 / 8EI$ Where,

a = length of overhang on each side

W = load applied at the free ends L

= main span

E = modulus of elasticity of the material of the

beam I = moment of inertia of cross section of the

beam $EI = w.a. L^2 / 8y$

It is known that, EI for beam = $E \times bd^3 / 12$

Where, b = width of beam

d = depth of beam

Procedure: -

- i) Find b and d of the beam and calculate the theoretical value of EI by Eq. (3).
- ii) Measure the main span and overhang span of the beam with a scale.
- iii) By applying equal loads at the free end of the overhang beam, find the central deflection y.
- iv) Repeat the above steps for different loads.

- Observation: -**
- 1) Length of main span, L (cm) =
 - 2) Length of overhang on each side, a (cm) =
 - 3) Width of beam, b (cm) =
 - 4) Depth of beam, d (cm) =
 - 5) Modulus of elasticity, E (kg/cm²) = 2×10^6

Observation Table:-

Sr. No.	Equal loads at the two ends (kg)	Dial gauge reading at the midspan of beam (cm)	EI from Eq. (3)	EI from Eq (2)

Calculation: - Average values of EI from observation =cm⁴
 Average values of EI from calculation =cm⁴

Result :- Flexural rigidity (EI) is found same theoretically and experimentally.

Precaution : - Measure the center deflection y very accurately.
 Ensure that the beam is devoid of initial curvature.
 Loading should be within the elastic limit of the materials.

EXPERIMENT NO. 6

Aim : - To determine the deflection of a pin connected truss analytically & graphically and verify the same experimentally.

Apparatus: - Truss Apparatus, Weight's, Hanger, Dial Gauge, Scale, Verniar caliper.

Diagram:-

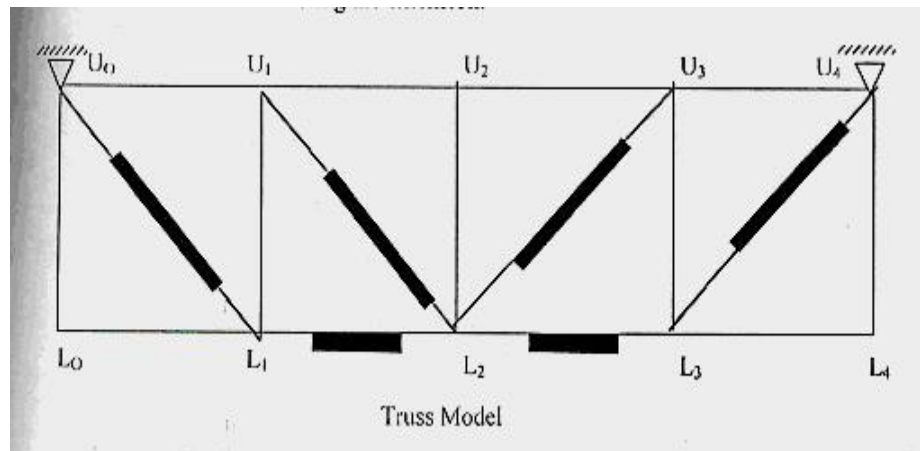

Theory :-The deflection of a node of a truss under a given loading is determined by:

$$\delta = \sum (TUL/AE)$$

Where, δ = deflection at the node point.

T = Force in any member under the given loading.

U = Force in any member under a unit load applied at the point where the deflection is required. The unit load acts when the loading on the truss have been removed and acts in the same direction in which the deflection is required.

L = Length of any member.

A = Cross sectional area of any member.

E = Young's modulus of elasticity of the material of the member.

Here, (L/AE) is the property of the member, which is equal to its extension per unit load. It may be determined for each member separately by suspending a load from it and noting the extension.

Procedure: -

i) Detach each spring from the member. Plot extension against load by suspending load from the spring and noting the extension. From the graph, obtain the extension per unit load (stiffness).

ii) For initial position of the truss, load each node with 0.5 kg load to activate each member. Now place the dial gauges in position for measuring the deflections and note down the initial reading in the dial gauges.

iii) Also put additional load of 1kg, at L1, 2kg, L2, and 1kg at L3, and note the final reading in the dial gauges. The difference between the two readings will give the desired deflection at the nodal points. Central deflection y .

iv) Calculate the deflection for the three nodes L1, L2, and L3 from the formula given in Eq. (1) and compare the same with the experimental values obtained in step 3.

v) Draw the Willot – Mohr diagram for deflection and compare the deflection so obtained experimentally and analytically.

Observation Table:-

Experimental Deflection Values

S.No.	Node Deflection	L1	L2	L3
1	Initial dial gauge reading (mm)			
2	Additional loads (kgs)			
3	Final dial gauge Reading (mm)			
4	Deflection (3) – (1) (mm)			

Analytical Calculation

Member	L/AE	F (kg)	Node L ₁		Node L ₂		Node L ₃	
			U (kg)	FUL/AE	U (kg)	FUL/AE	U (kg)	FUL/AE
U ₀ U ₁								
U ₁ U ₂								
U ₂ U ₃								
U ₃ U ₄								
L ₀ L ₁								
L ₁ L ₂								
L ₂ L ₃								
L ₃ L ₄								
U ₀ L ₀								
U ₁ L ₁								
U ₂ L ₂								
U ₃ L ₃								
U ₄ L ₄								
U ₀ L ₁								
U ₁ L ₂								
U ₃ L ₂								
U ₄ L ₃								

Sample Calculation: - Member =.....
 L/AE =
 Analytical deflection:= FUL/AE

Result :-The theoretical and experimental deflection in various members is found same.

Precaution : - i) Apply the loads without any jerk.
ii) Measure the deflection to the nearest of a millimeter.
iii) Perform the experiment at a location, which is away from any
iv) external disturbance.
v) Ensure that the supports are rigid.

EXPERIMENT NO. 7

Aim: - To verify the Muller Breslau theorem by using Begg's deformer set.

Apparatus :- Muller Breslau Principal Begg's Deformeter, Micrometer , Microscope, Functioning plugs, Influence line ordinates, Drawing board , Pins etc.

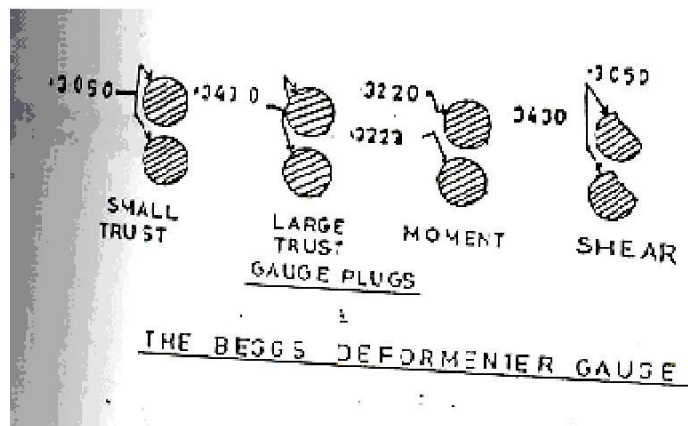
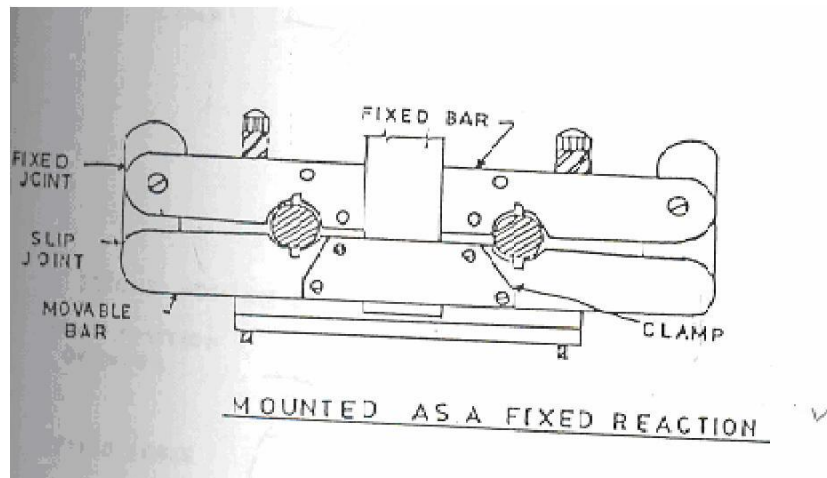
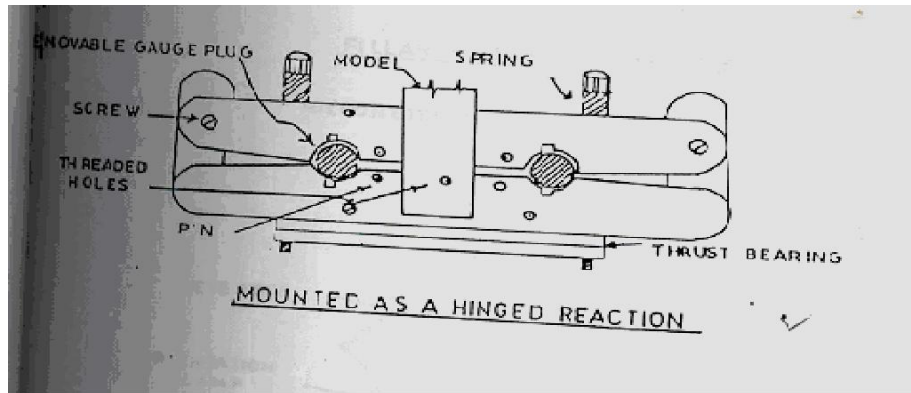

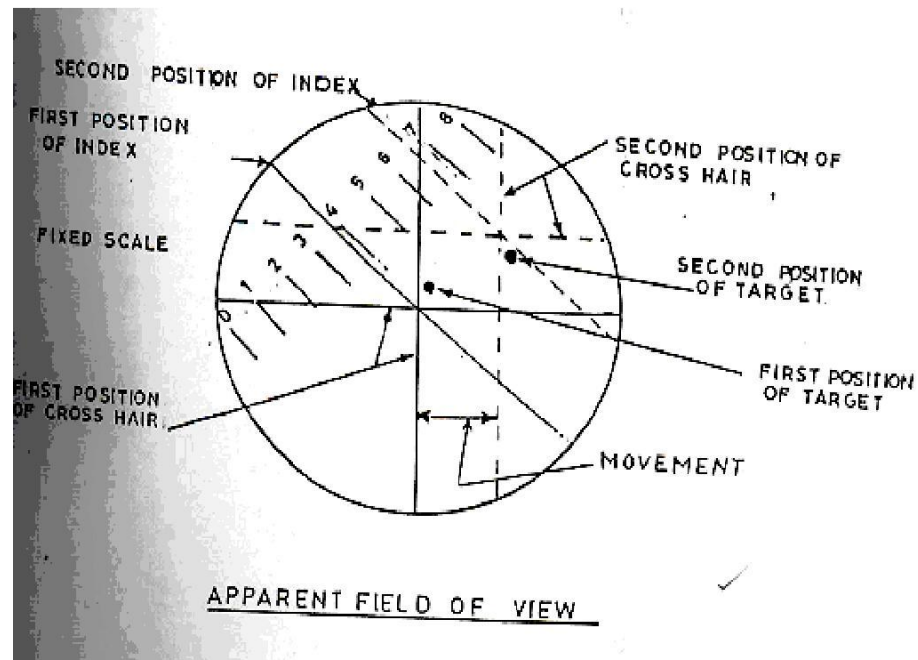
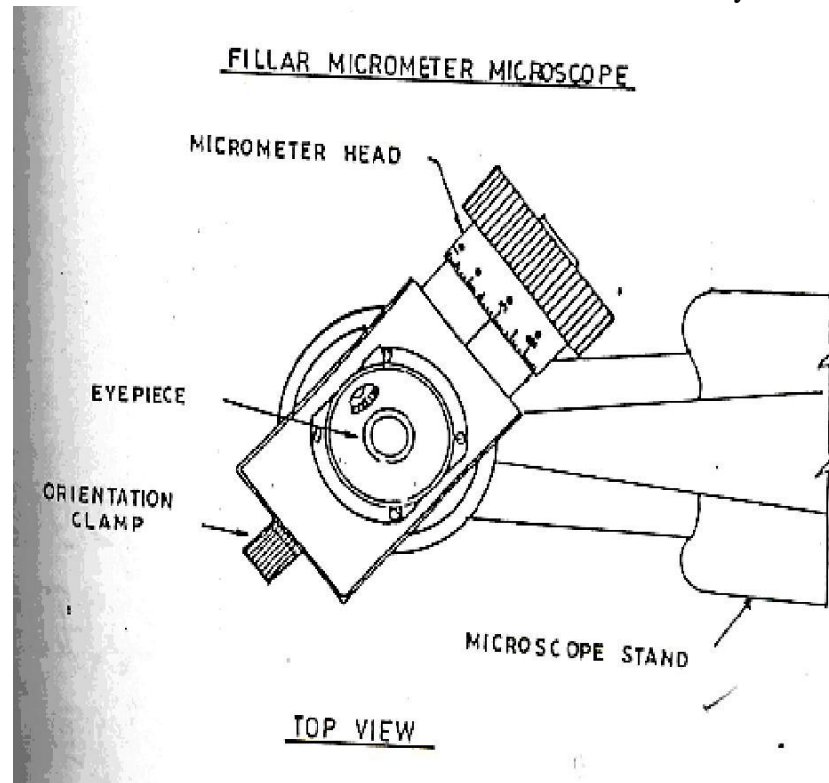

Theory :- Various methods are available to verify Muller Breslau's Principle such as Brass wire Method, Begg's Deformeter, Eney Deformeter and Gottschalk Continostat method. The Begg's Deformeter Method is usually the most satisfactory experimental method. This principle states "the ordinates of the influence lines for any stress element (such as axial stress, shear moment or reaction) at any section of the structure are proportional to those of the deflection curve which is obtained by removing the restraint corresponding to that element from the structure and introducing in its place a deformation in to the primary structure which remains.

This principle is applicable to any type of structure whether statically determinate or indeterminate. In case of indeterminate structures this principle is limited to structures, the material of which is elastic and follows Hook's law.

The application of Begg's deformer apparatus involves the use of the relation.

$$F_2 = k p_n (\delta_n / \delta_2)$$

F_2 = desired force component at point 2, produced by p_n .

p_n = force assumed to be acting on structures at point n.

k = a constant; scale reduction factor if F_2 is a moment component or unity if F_2 is a thrust or shear component.

δ_n = deformation introduced at point 2 in the direction of F_2 .

δ_2 = deformation introduced at point n caused by F_2 and measured in the direction of p_n

Procedure: -

- i) Choose the problem for the study e.g. portal frame of equal / unequal legs, beams, trusses or any other structures.
- ii) Choose the scale reduction factor for the linear dimensions that will give a model of a size to be made easily and used conveniently. For most structures this factor will be of such a value as to allow the model to be cut from a standard sheet.
- iii) Select the material for model e.g. plastic sheet/Acrylic/Perspex or any other desired sheet. The width and thickness should remain same throughout the length used.
- iv) Cut the model in the selected shape /size .Mark the center line throughout the model length otherwise every time one should have to find out the centre.

Observation Table: -

Table - 1

Calibration of Plugs:-

S. No	Points	Thrust	Shear	Moment	Calibration constant

Table - 2

Influence Line Ordinates:-

S. No	Points	Thrust		Shear		Moment	
		Observed	Calculated	Observed	Calculated	Observed	Calculated
	1.						
	2.						
	3.						

Calculation: - The ordinate of influence line diagram obtained experimentally:
The ordinate of influence line diagram obtained analytically:

Result : - The Muller Breslau Principle is verified experimentally and analytically.

Precaution: -

- i) Apply the loads without any jerk.
- ii) Measure the deflection to the nearest of a millimeter.
- iii) Perform the experiment at a location, which is away from any
- iv) Avoid external disturbance.
- v) Ensure that the supports are rigid.

EXPERIMENT NO. 8

Aim: - To verify Clerk Maxwell's reciprocal theorem

Apparatus: - Clerk Maxwell's Reciprocal Theorem apparatus, Weight's, Hanger, Dial Gauge, Scale, Verniar caliper.

Diagram:-



Theory :-

Maxwell theorem in its simplest form states that deflection of any point A of any elastic structure due to load P at any point B is same as the deflection of beam due to same load applied at A

It is, therefore easily derived that the deflection curve for a point in a structure is the same as the deflected curve of the structure when unit load is applied at the point for which the influence curve was obtained.

Procedure: -

- i) Apply a load either at the centre of the simply supported span or at the free end of the beam, the deflected form can be obtained.
- ii) Measure the height of the beam at certain distance by means of a dial gauge before and after loading and determine the deflection before and after at each point separately.
- iii) Now move a load along the beam at certain distance and for each positions of the load, the deflection of the point was noted where the load was applied in step1. This deflection should be measured at each such point before and after the loading, separately.
- iv) Plot the graph between deflection as ordinate and position of point on abscissa the plot for graph drawn in step2 and 3. These are the influence line ordinates for deflection of the beam.

Observation Table:-

Distance from the pinned end	Load at central point/cantilever end		Deflection of various points (mm) 2-3	Load moving along beam		Deflection of various points (mm) 5-6
	Beam unloaded Dial gauge reading (mm)2	Beam loaded Dial gauge reading (mm)3	Beam unloaded Dial gauge reading (mm)5	Beam unloaded Dial gauge reading (mm)5	Beam loaded Dial gauge reading (mm)6	

Result :- The Maxwell reciprocal theorem is verified experimentally and analytically.

- Precaution:** -
- i) Apply the loads without any jerk.
 - ii) Perform the experiment at a location, which is away from any
 - iii) Avoid external disturbance.
 - v) Ensure that the supports are rigid.

EXPERIMENT NO. 9

Aim: - To determine material fringe value by using diffused light research polariscope.

Apparatus: - Diffused light research polariscope, photo elastic model.

Diagram:-

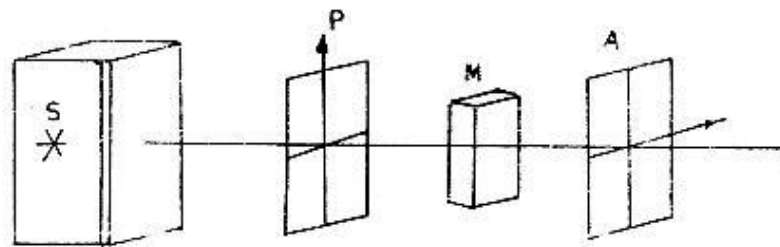

PLANE POLARISCOPE

Theory : - Plane Polariscope

Plane Polaris cope is used for obtaining the **ISOCLINIC LINE- PATTERN** The dark band which contains all the prints whole σ_1 & σ_2 direction are the same are called ISOCLINICS.

This isoclinic is the locus of all points where direction σ_1 & σ_2 are the same.

Extinction of the light will be seam at all point where σ_1 & σ_2 are parallel to Analyses & Polarizer axes.

This particular fact is very useful in determining the directions of principal stresses at any point in the loaded model. When P&A axes are vertical & Horizontal them a dark line seem is the focus of points where σ_1 & σ_2 directions are Vertical & Horizontal.

If one measures angles from vertical ref. Axis, this isoclinic will be called zero degree

ISO now rotate the P this 30° & A also there 30° move 0 isoclinic will vanish & new dark line is seem this is 30°

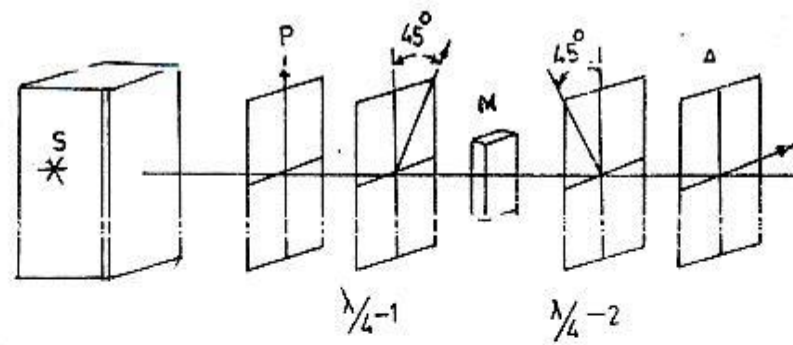
Circular PolariscopesCIRCULAR POLARISCOPE

- 1) S - SOURCE OF LIGHT
- 2) P - POLARISER
- 3) $\lambda/4-1$ QUARTER WAVE PLATE -1
- 4) M - PHOTO ELASTIC MODEL
- 5) $\lambda/4-2$ QUARTER WAVE PLATE -2
- 6) A - ANALYSER.

Using monochromatic light source, from the circular polariscope, pure ISOCHROMATICS are obtained. Isochromatics are blank & white bands in dictating the points of equal phase difference develop due to temporary double refraction in the model.

In the standard crossed - crossed type circular polariscope , fringe in a stress pattern corresponds to a phase difference of one or an integral no. of whole wave length i.e. fringe order $n = 0, 1, 2, 3, 4, \dots$ etc. while white light filter gives the fringes of order of $n = \frac{1}{2}, 1\frac{1}{2}, 2\frac{1}{2}, 3\frac{1}{2}, \dots$ etc.

ISO chromatic curves (bands) are the Loci of points of constant principal stress difference of constant shear stress lines they are the lines of equal $\sigma_1 - \sigma_2$ values with increasing order of stresses from $n = 0, 1, 2, \dots$ etc.

Procedure: -

- i) Determine the direction of principle stress at desired point A by using plane polariscope with white light.
- ii) Orient quarter wave plate properly to transfer plane polariscope into circular.

iii) Using monochromatic light sources, if quarter wave plates are introduced to transfer circular polariscopoe in the crossed condition, then black bond will be of full integer order.

iv) Rotate analyzer only till exact fringe is achieved at desired point. length of rotation of analyzer is

$$\Delta = N + \alpha/180^0$$

v) If rotating the analyzer through 36^0 in the clockwise direction, the exact fringe formed for third order to point A.

$$\Delta_A = 3 + 36^0/180^0$$

If analyzer is notated anticlockwise, the fringe formed will be of nth order, and then it will be

$$\Delta_A = H + 144^0/180^0 = 3.2$$

Observation Table:-

Sr. No.	Force in kg.	N	α	$\Delta = N + \alpha/180^0$

Calculation: - $\Delta_A = H + \dots^0/180^0 = \dots\dots$

Result :-The material fringe order can be easily calculated by using plane polariscope.

Precaution: - Use correct source of light.

Perform the experiment away from vibration and other disturbances.

EXPERIMENT NO. 10

Aim: - To verify the moment area theorem regarding the slopes and deflections of the beam.

Apparatus: - Moment of area theorem apparatus.

Diagram:-

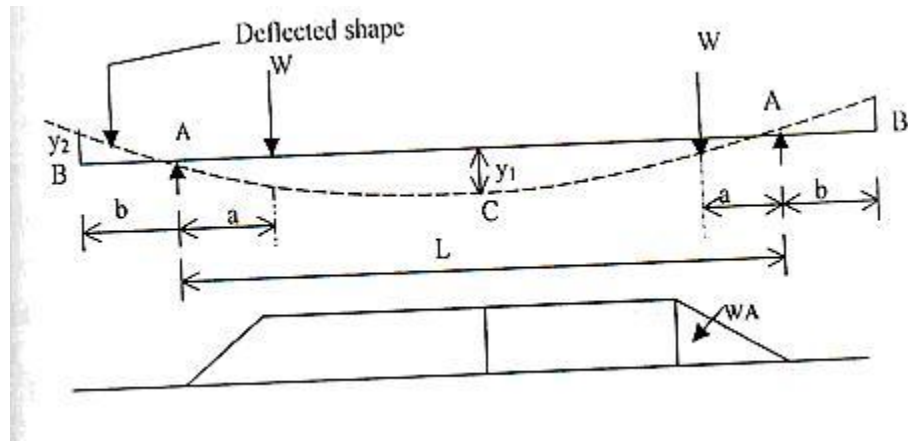

Theory :-

According to moment area theorem

1. The change of slope of the tangents of the elastic curve between any two points of the deflected beam is equal to the area of M/EI diagram between these two points.
2. The deflection of any point relative to tangent at any other point is equal to the moment of the area of the M/EI diagram between the two point at which the deflection is required.

$$\text{Slope at B} = Y_2 / b$$

Since the tangent at C is horizontal due to symmetry,

$$\text{Slope at B} = \text{shaded area} / EI = 1 / EI [Wa^2 / 2 + WA (L/2 -$$

a)] Displacement at B with respect to tangent at C

$$= (y_1 + y_2) = \text{Moment of shaded area about B} / EI$$

$$= 1 / EI [Wa^2 / 2 (b+2/3a) + Wa(L/2 -a)(b+ a/2+L/2)]$$

Procedure: -

1. Measure a, b and L of the beam
2. Place the hangers at equal distance from the supports A and load them with equal loads.

3. Measure the deflection by dial gauges at the end B (y_2) and at the center C (y_1)

4. Repeat the above steps for different loads.

Observation Table:-

Length of main span, L (cm) =

Length of overhang on each side, a (cm) =

Modulus of elasticity, E (kg/cm^2) = 2×10^6

Sl . No.	Load at each Hanger (kg)	Central Deflection Y_1 (cm)	Deflection at Free end y_2 (cm)	Slope at B Y_2 / b	Deflection at C = Deflection at B (y_1)

Calculation:-

1. Calculate the slope at B as y_2 / b (measured value).
2. Compute slope and deflection at B theoretically from B.M.D. and compare with experimental values.
3. Deflection at C = y_1 (measured value).
4. Deflection at C = Average calculated value

Result :- The slope and deflection obtained is close to the slope and deflection obtained by using moment area method.

Precaution:-

- . Apply the concentration loads without jerks.
- . Measures the deflection only when the beam attainsion.
- . Measures the deflection very care fully and accurately.
- . Check the accuracy and least count of dial gauges used for measuring deflections.

EXPERIMENT NO 11

Aim: - To determine the moment required to produce a given rotation (rotational stiffness) at one end of the beam when the other end is pinned.

Diagram:

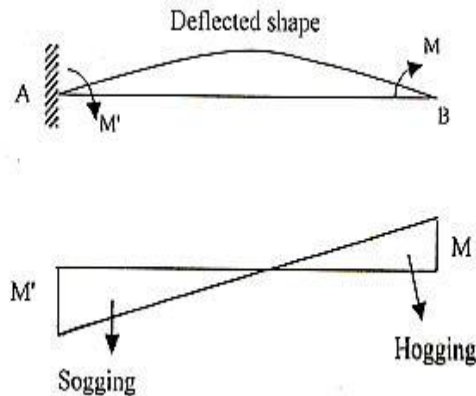

Theory :-

For a beam AB which is simply supported at A and fixed at B, a clock – wise rotation of θ_A can be effected by applying a clockwise moment of $M_A = \{ 4EI / L \} \times \theta_A$ at A, = stiffness X Rotation which in turn induces a clockwise moment of $M_B = 1 / 2 M_A$ on the member at B. The expression $M_A = \{ 4EI / L \}$ is called the stiffness factor, which is defined as the moment required to be applied at A to cause a rotation of 1 radian at A of a span AB simply supported at A and fixed at B. The number $M_A / M_B = + 1 / 2$ is the carry over factor, which is the ratio of the moment induced at B due to the moment applied at A.

If the far end is hinged instead of being fixed, the moment required to rotate the tangent at the near end through 1 radian will be $3EI / L$ instead of $\{ 4EI / L \}$

Moment required to produce a given rotation at one end of the beam when the other end is pinned is $3 / 4$ th of the moment required to produce the same rotation when the other end is fixed.

Procedure: - (A) Beam with overhang having far end pinned.

1. Measure the height of free end C of the beam from the top of the table.
2. Load W is applied at the free end C. The beam will get deflected as shown in the Measure the height of the deflected end C from the table top. The difference will give the deflection y.

3. Measure the deflection Y at C and find the slope (Y/a) at A .

4. Repeat the above steps for different loads.

(B) Beam with overhang having far end fixed.

1. Repeat all the steps as in beam with far end connected.

A graph is plotted between moment as ordinate and slopes for pinned end and slopes for fixed end as abscissa.

Find the ratio of moments in the two cases for the same slope.

Observation Table:-

$a = \dots\dots\dots$ cm

Sr.No	Load W (kg)	Far end pinned		Far end fixed	
		Deflection y (cm)	Slope y / a radian	Deflection y (cm)	Slope y / a rad

Calculation: - Load = kg.

Deflection:

Slope:

Result : - The produced at one end of the beam when the other end is pinned is give by

Precaution:-

Measures the deflection of the free end C of the beam very accurately.

Apply the load at the free end without any jerks.

Perform this experiment away from any external disturbances.